

MSSOS

Simon a Campo
Simon Bavinck
Jasper Faber
Teun Keusters
Art Selbach

GOAL

WARMING UP

HEARTRATE

TEMPERATURE

EMG SIGNAL

SENSORS & PLACEMENT

TEMPRATURE SENSOR

NTC Thermistor

In-Ear Placement

SOURCE: NL.RS-ONLINE.COM

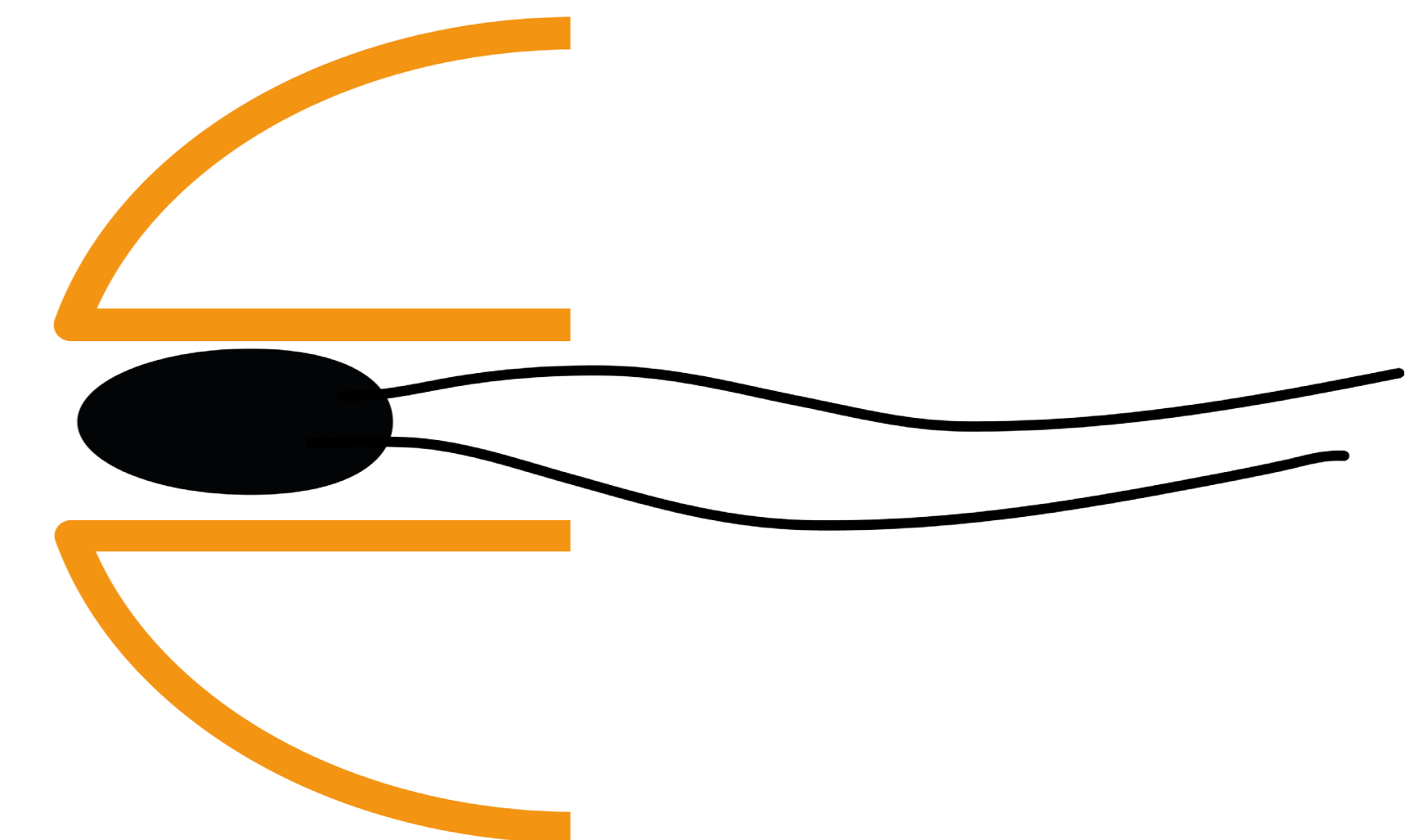

SENSORS & PLACEMENT

HEARTRATE SENSOR

Pulse Sensor

Optical

Placement on finger

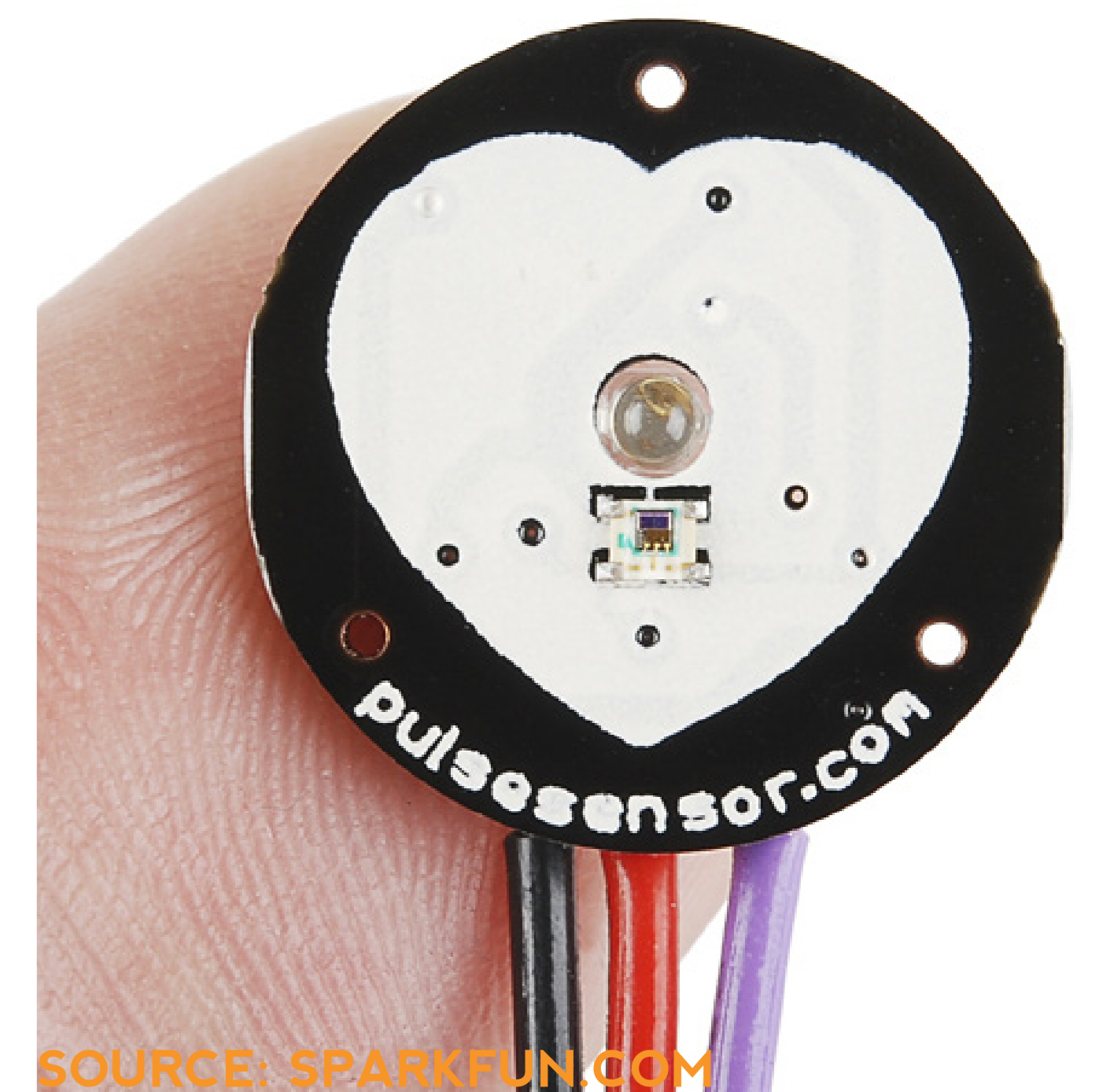

SENSORS & PLACEMENT

EMG SENSOR

Muscle Sensor V3

senses EMG signals

Adhevisive Electrodes

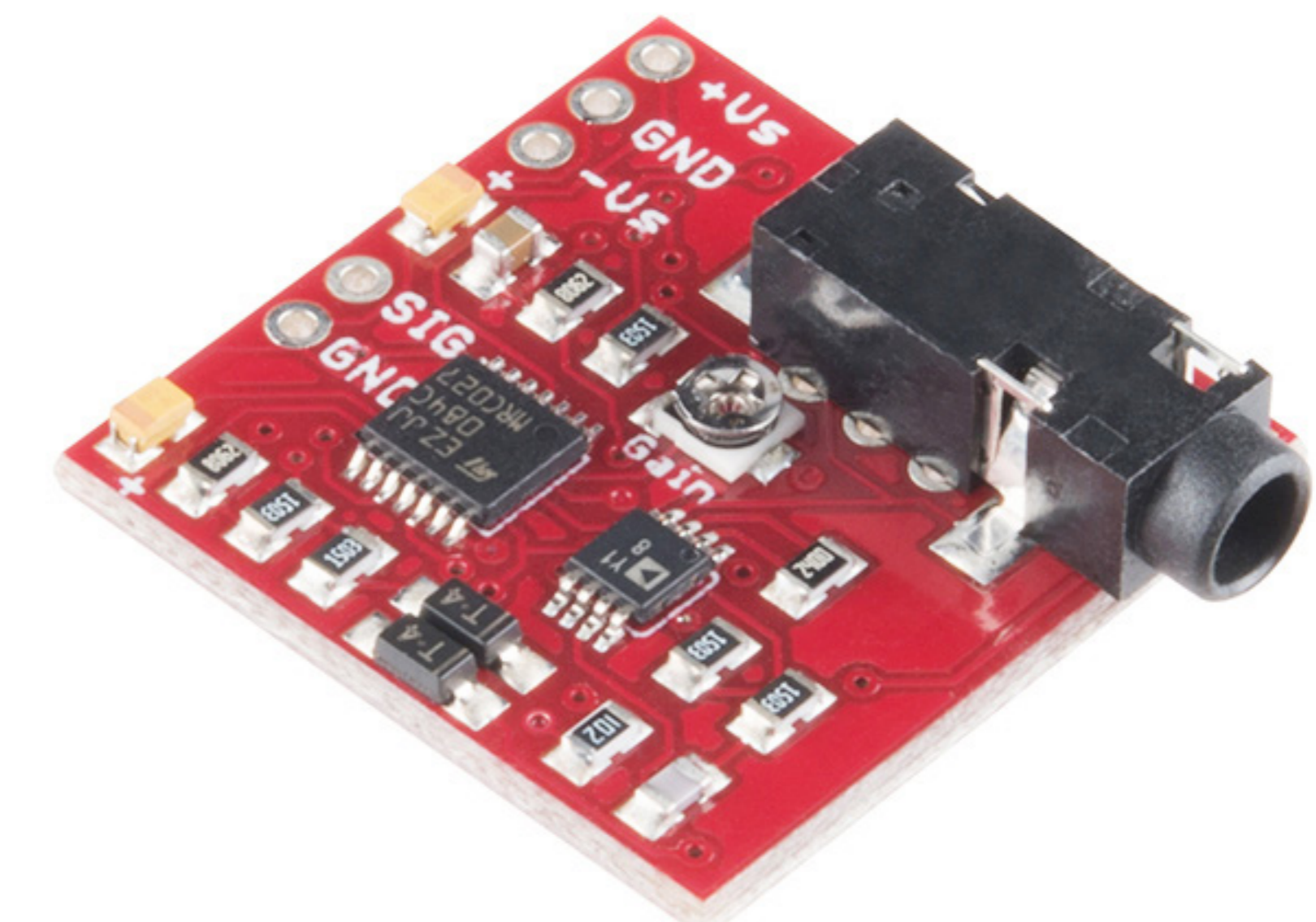

SOURCE: SPARKFUN.COM



SOURCE: SPARKFUN.COM

SENSORS & PLACEMENT

PLACEMENT OTHER COMPONENTS

Forearm

Phone-sportsband

3D printed casing

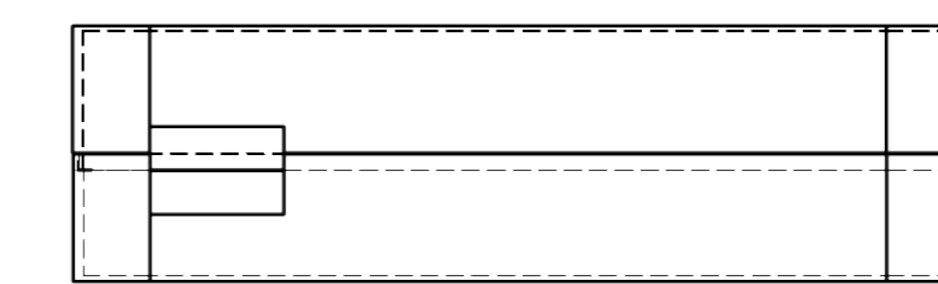
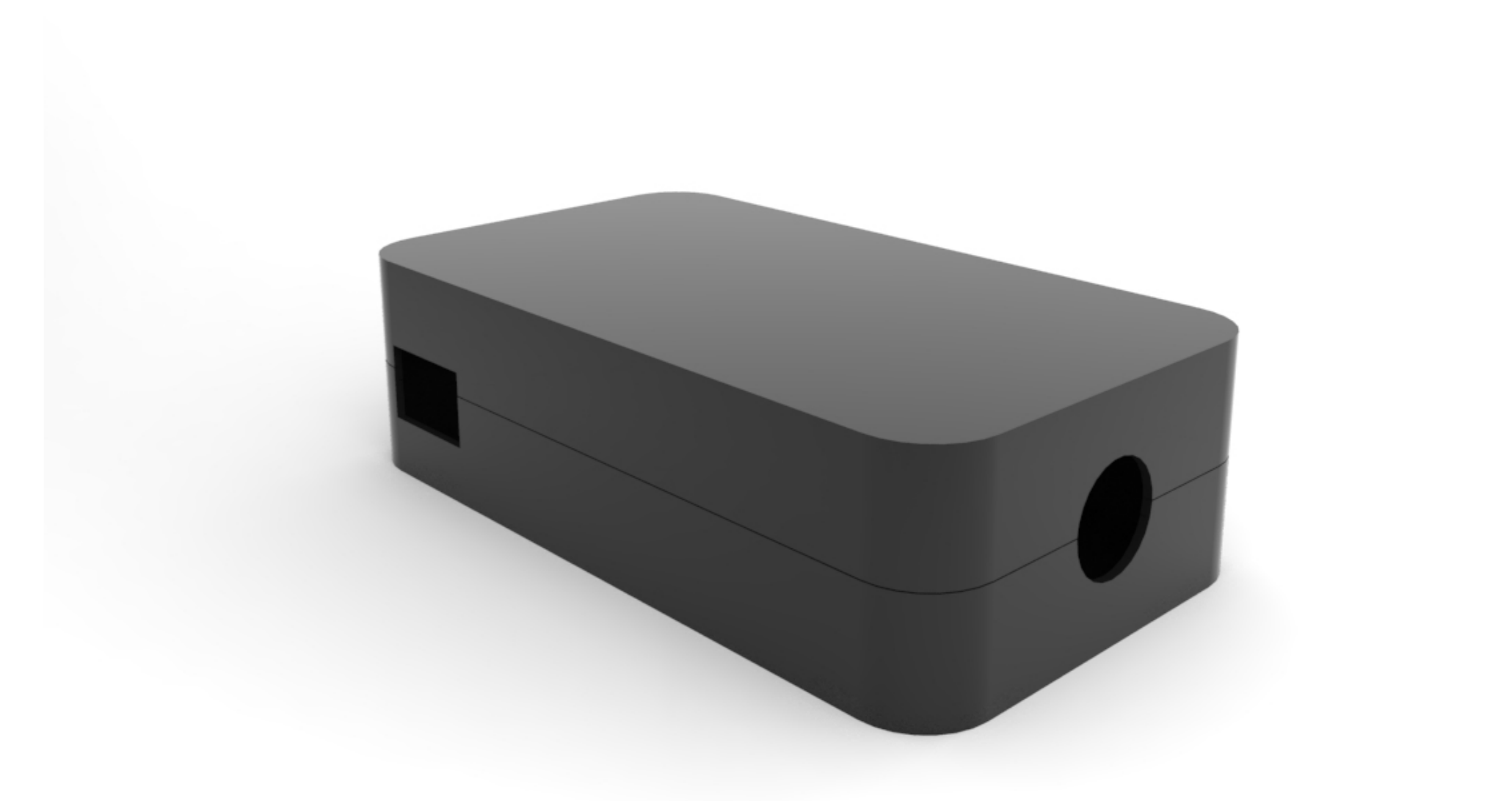

Left

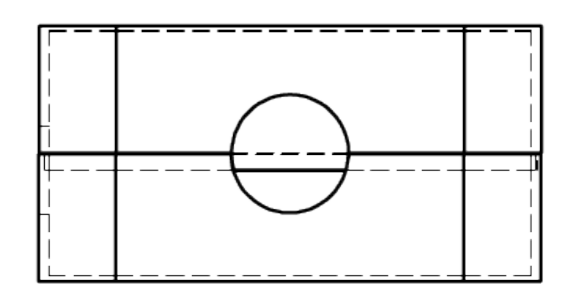

Front

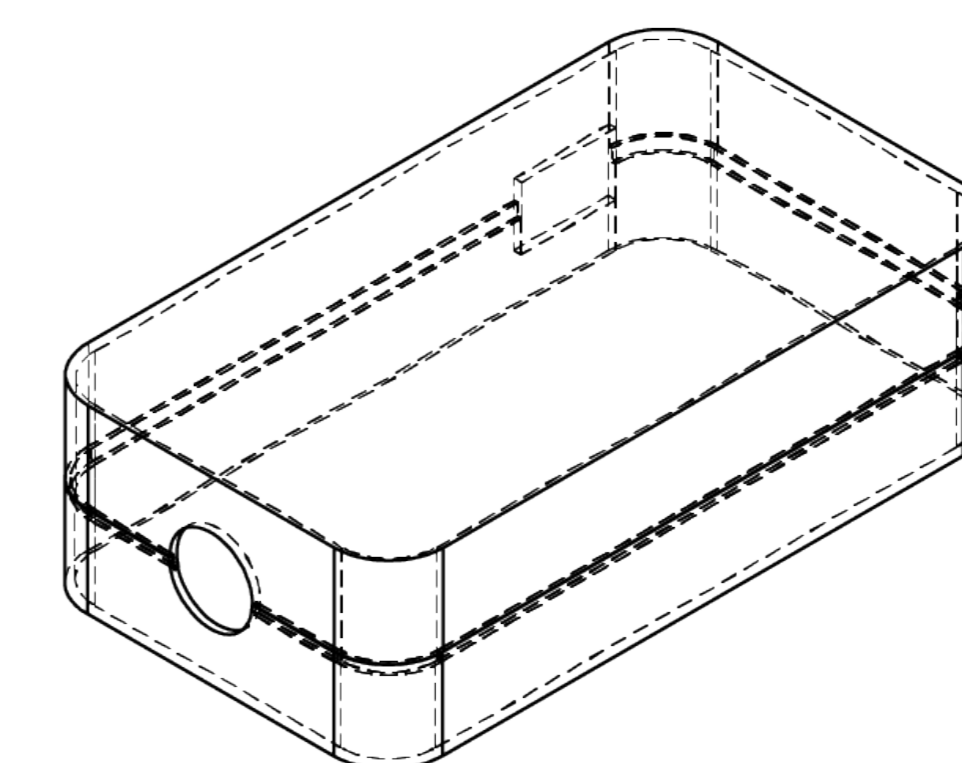

Front Right Top

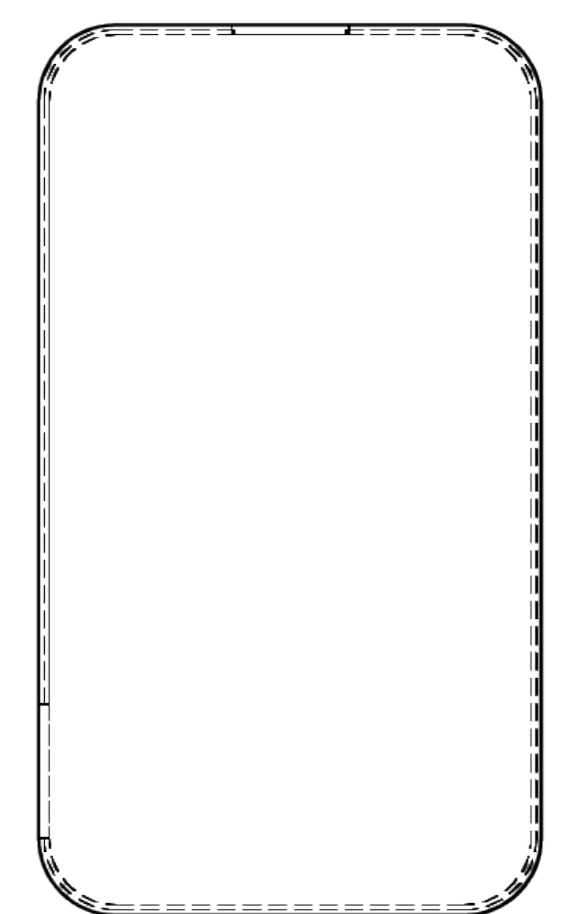

Top

ELECTRONIC CIRCUIT

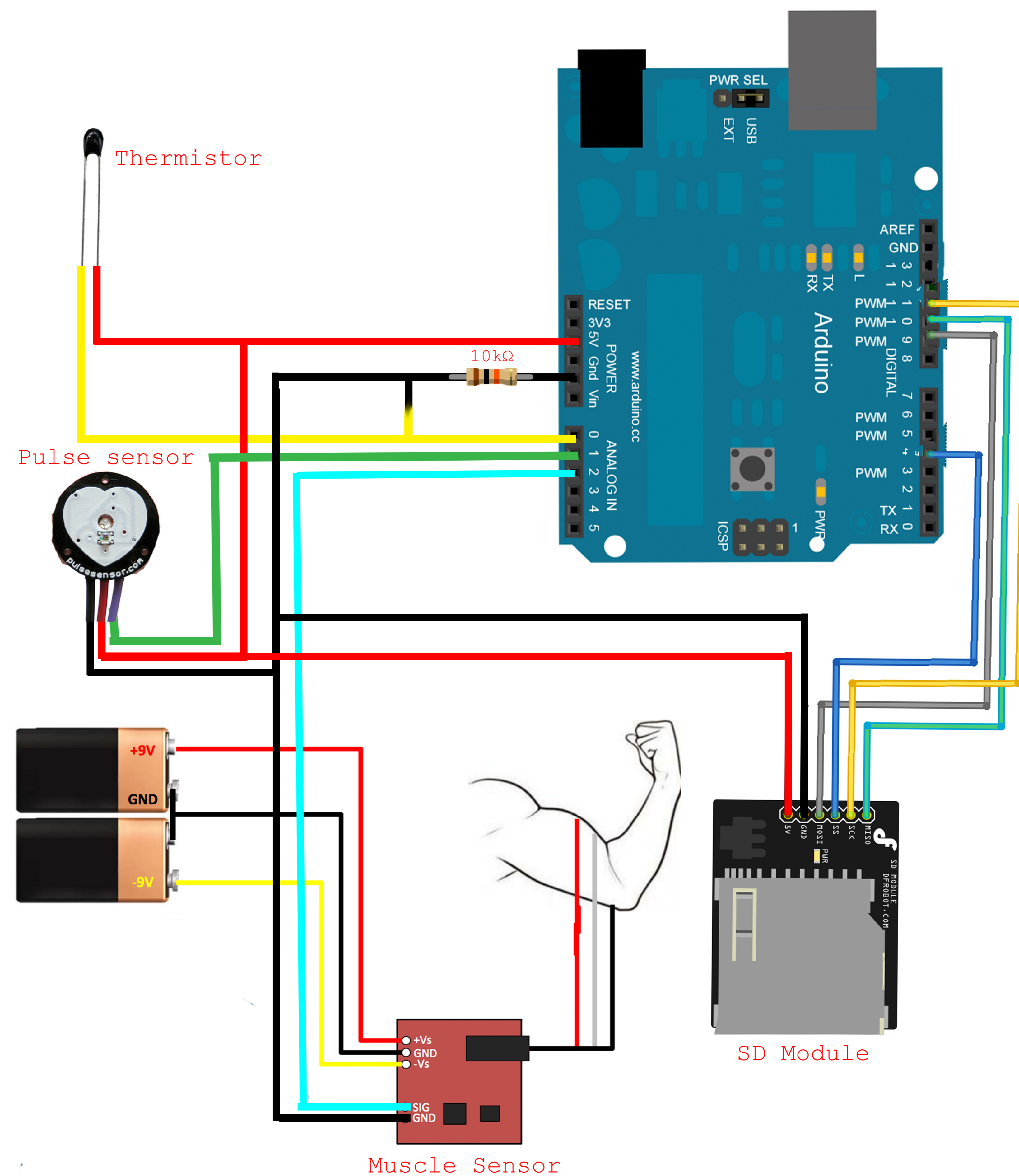

DATA ANALYSIS

THERMISTOR

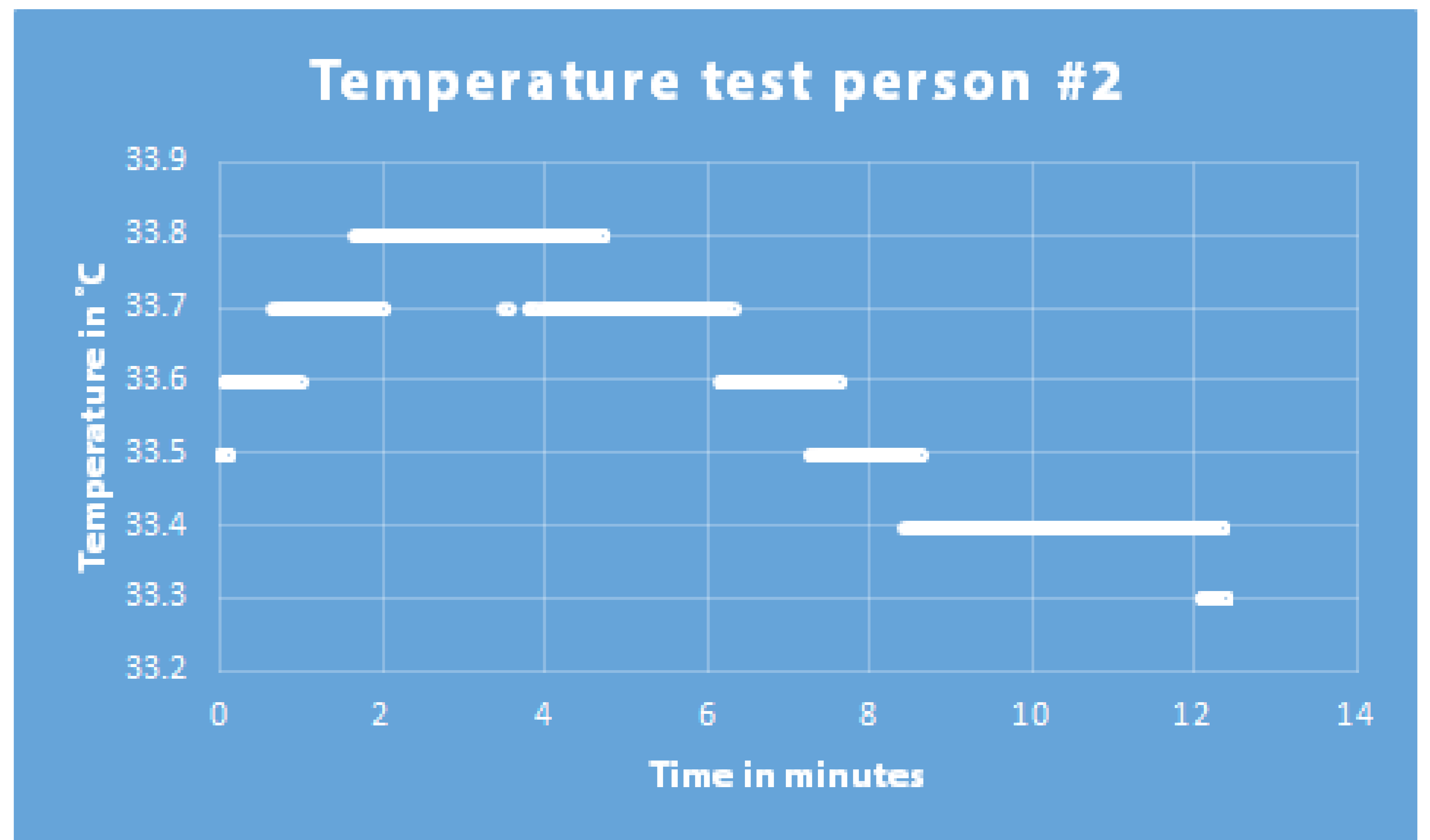

DATA ANALYSIS

THERMISTOR

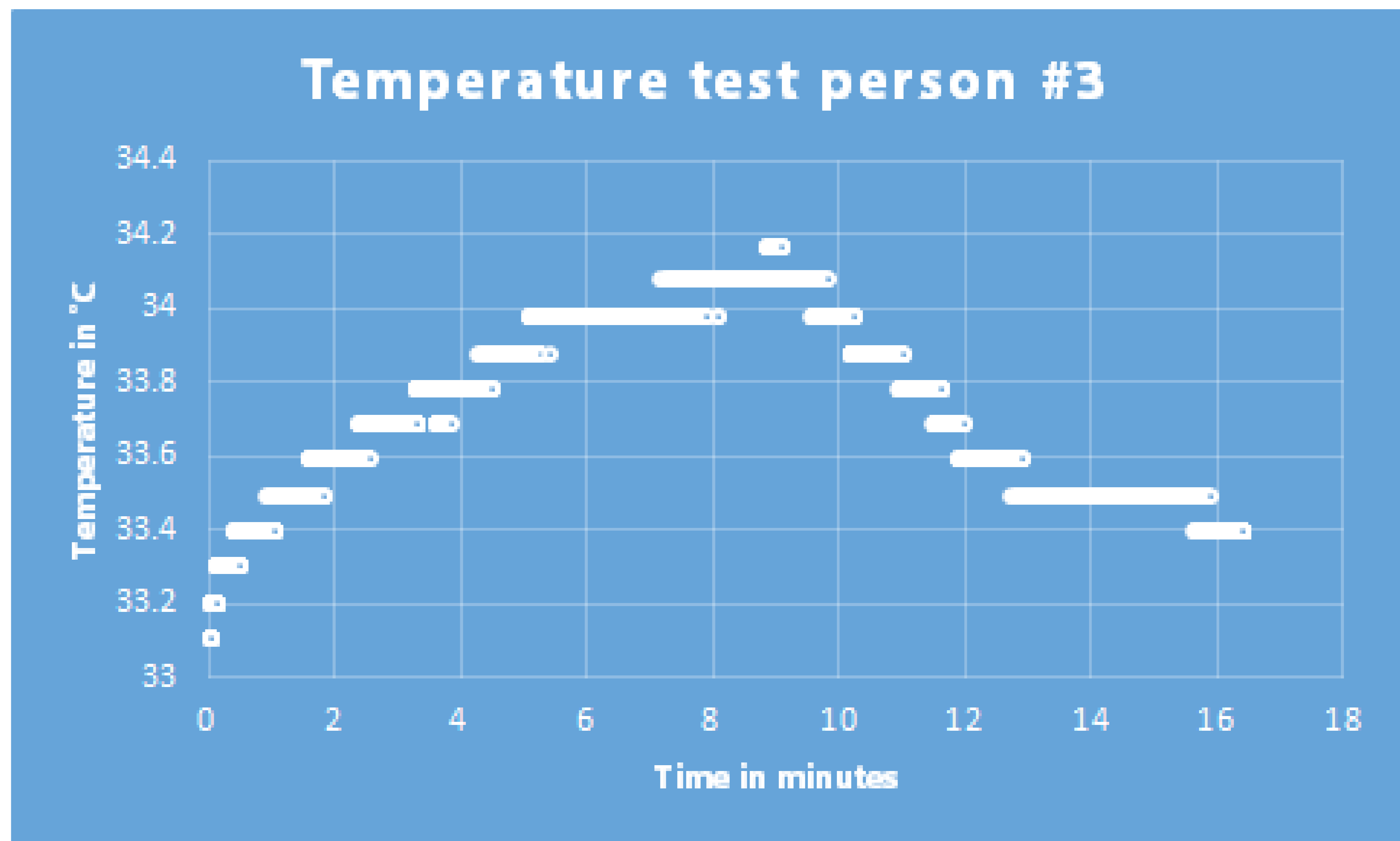

DATA ANALYSIS

THERMISTOR

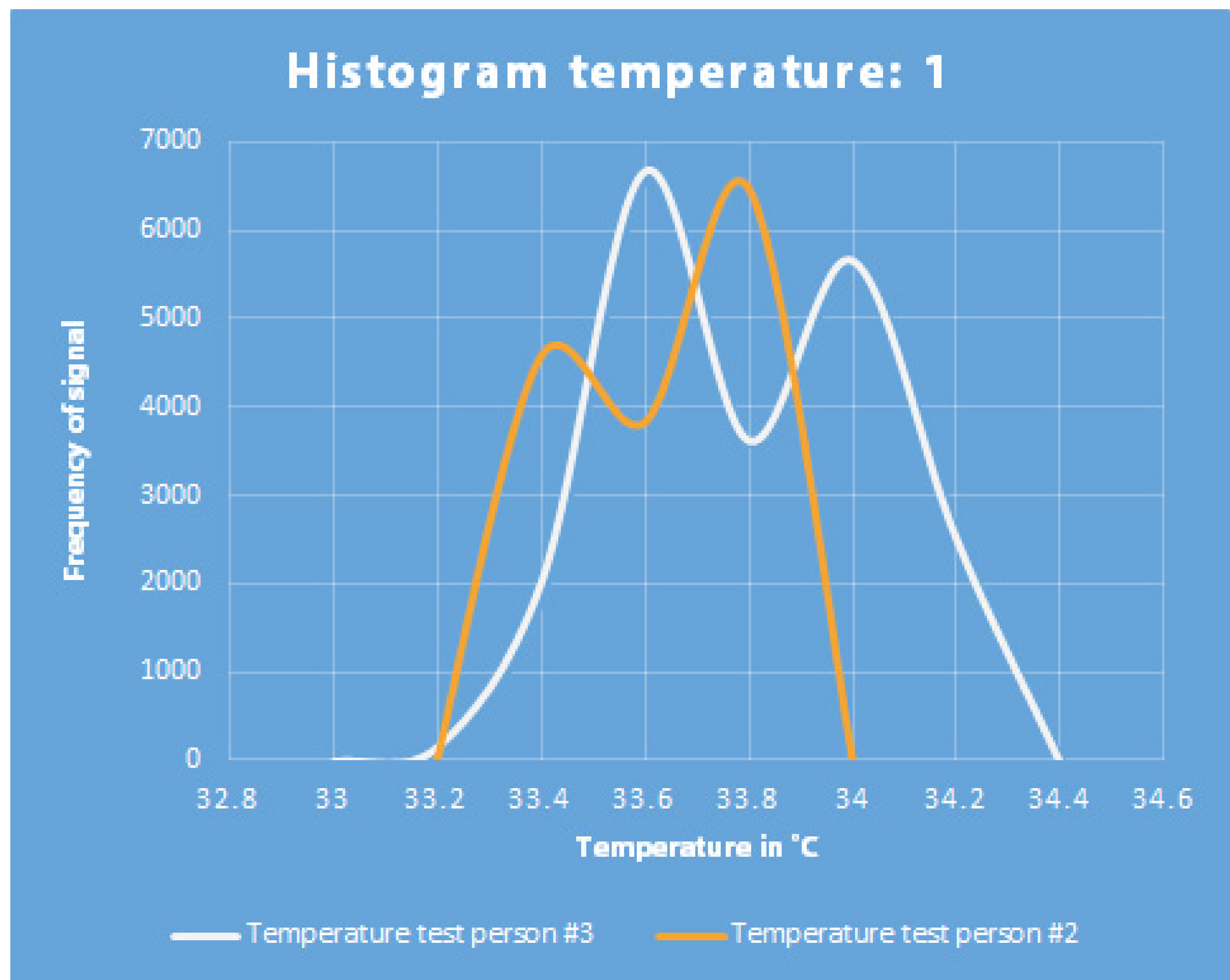

DATA ANALYSIS

HEARTRATE SENSOR TEST

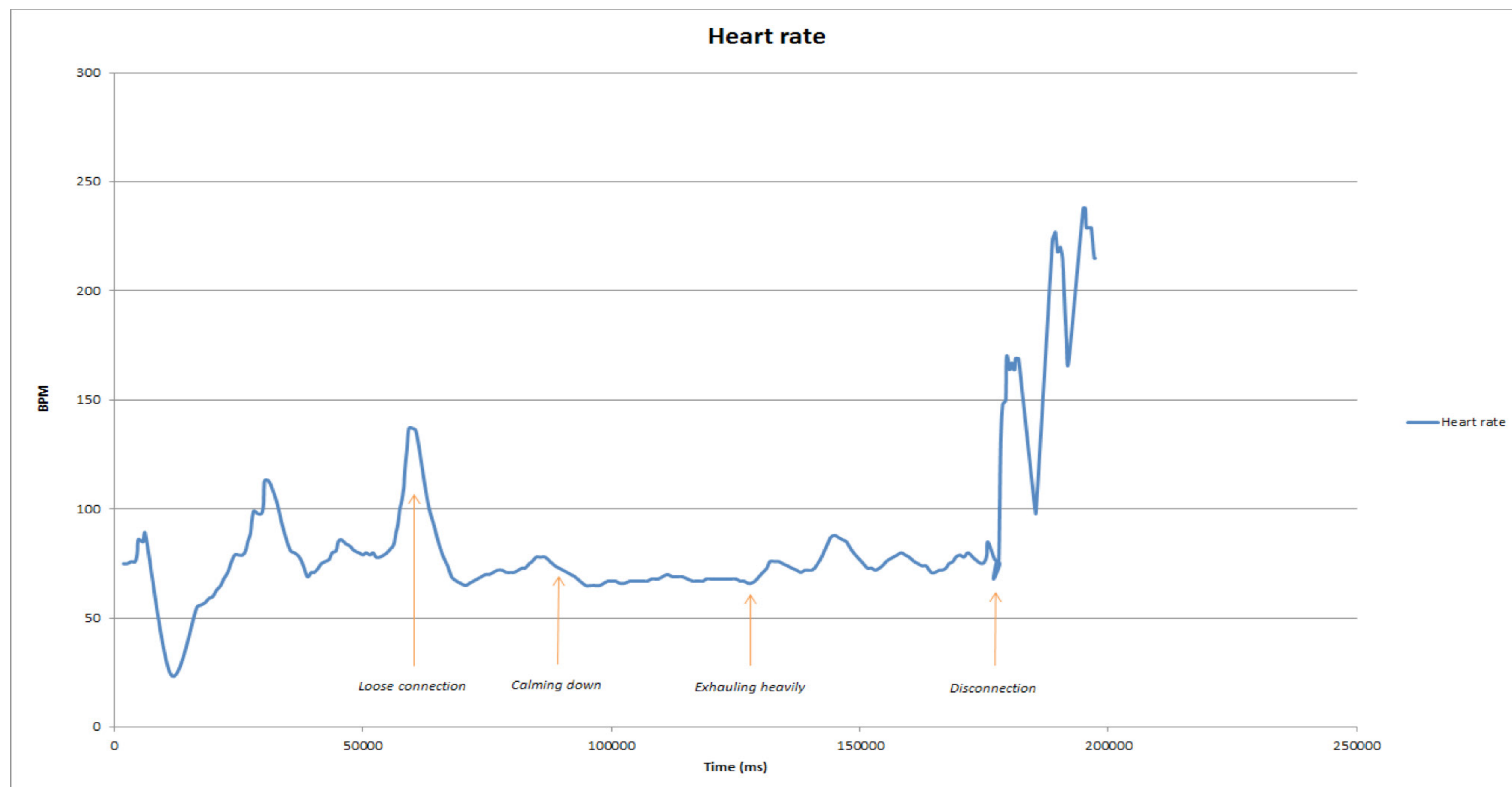

DATA ANALYSIS

HEARTRATE SENSOR TEST

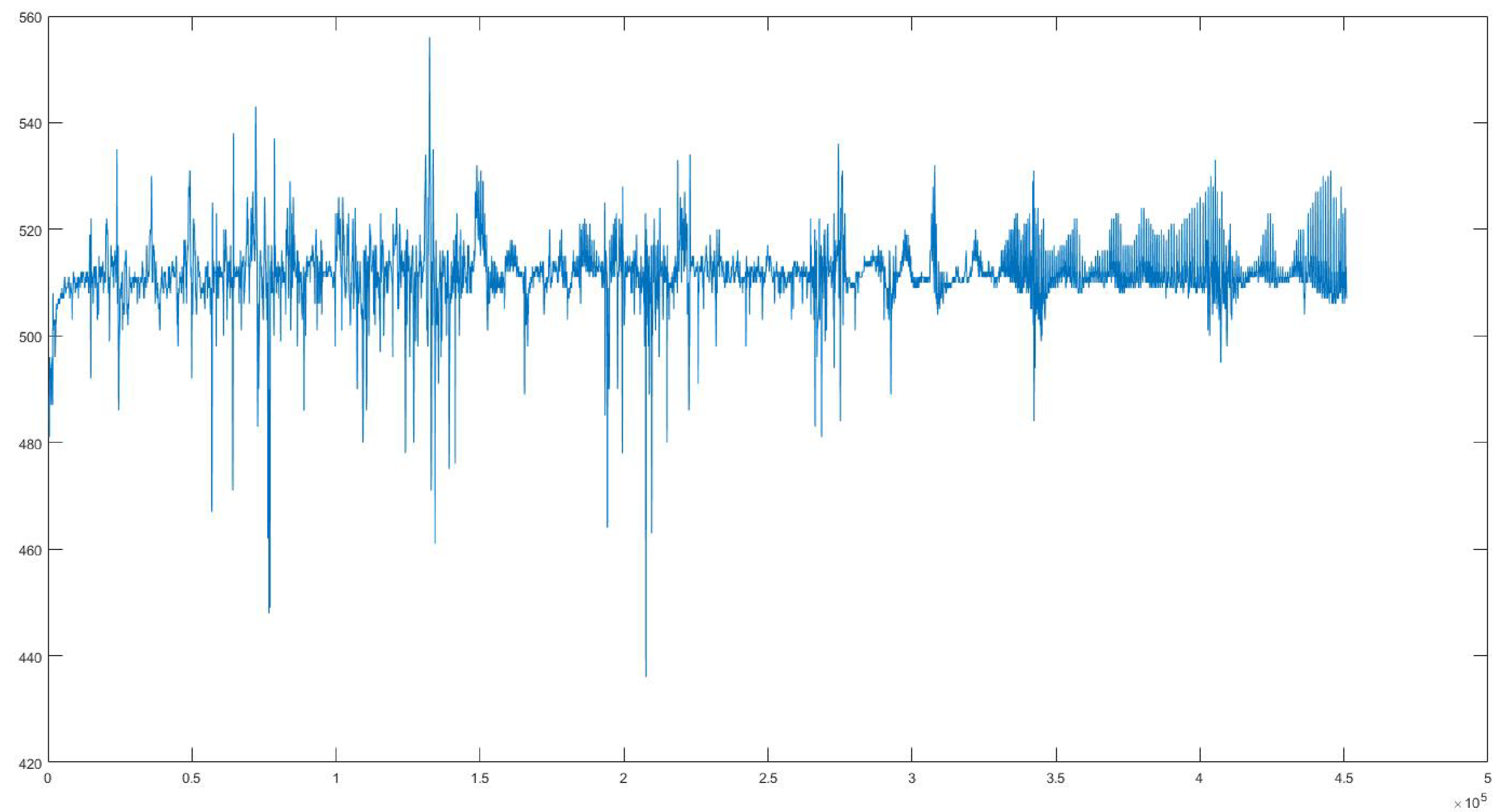

DATA ANALYSIS

EMG SENSOR TEST

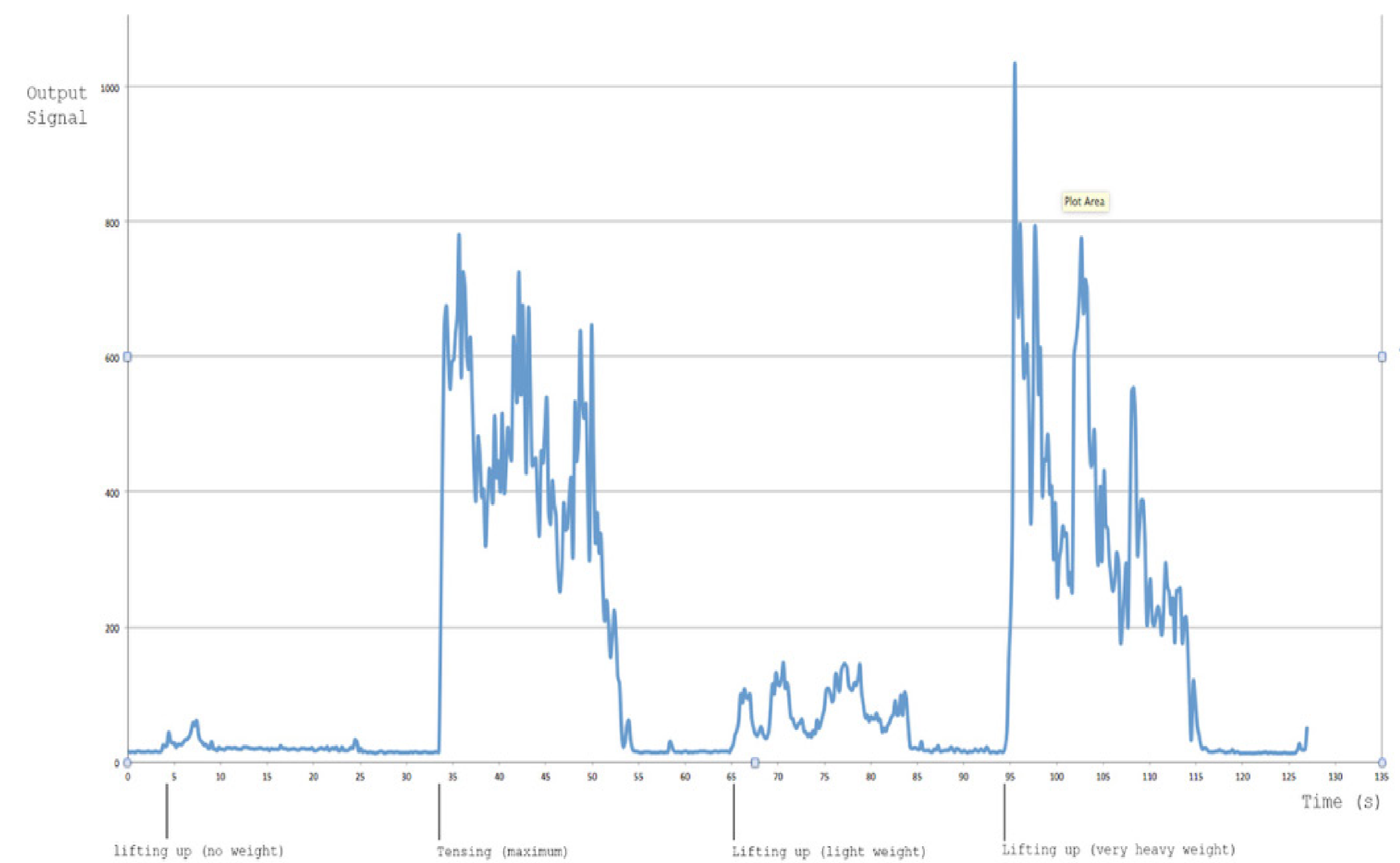

DATA ANALYSIS

EMG SENSOR

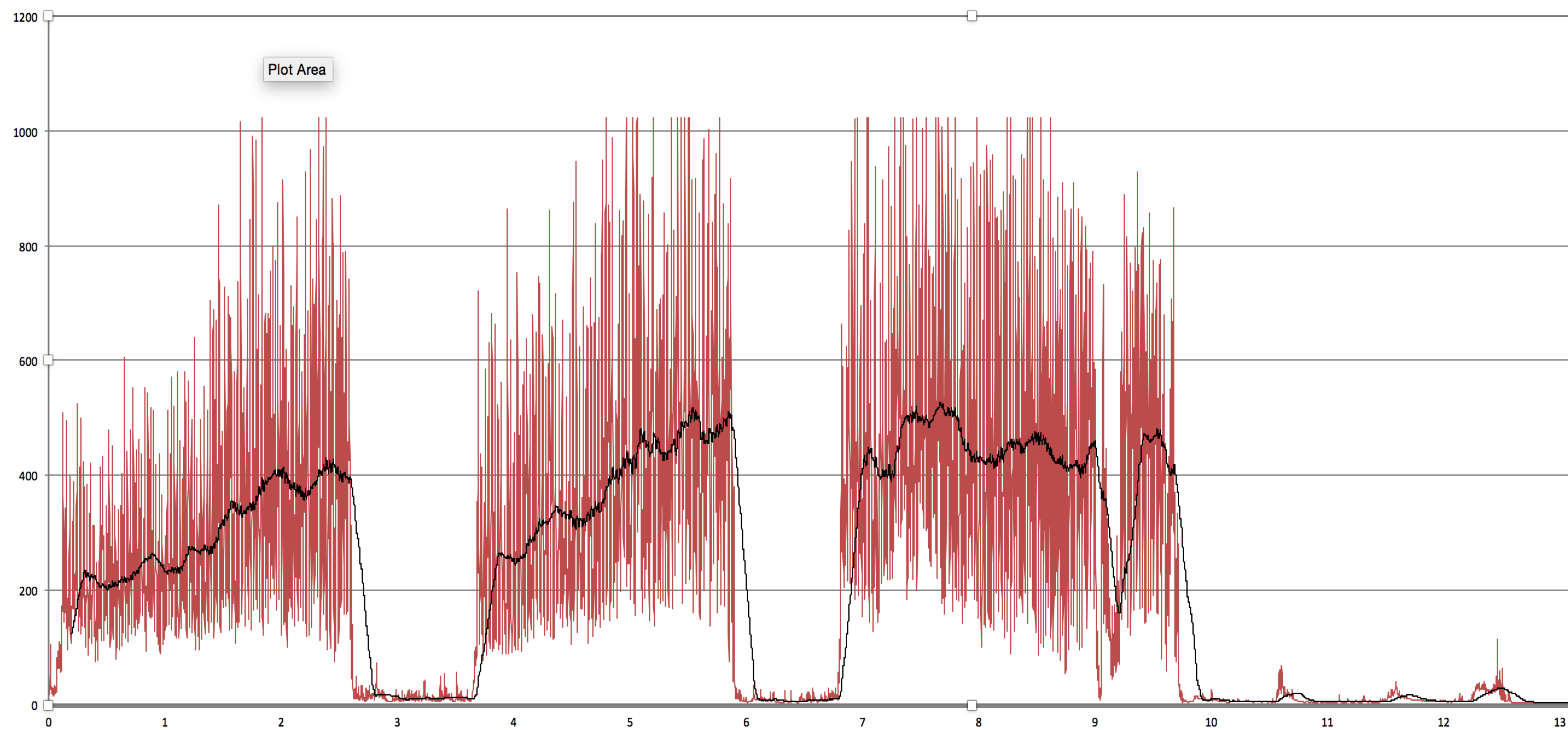

DATA ANALYSIS

EMG SENSOR HISTOGRAM

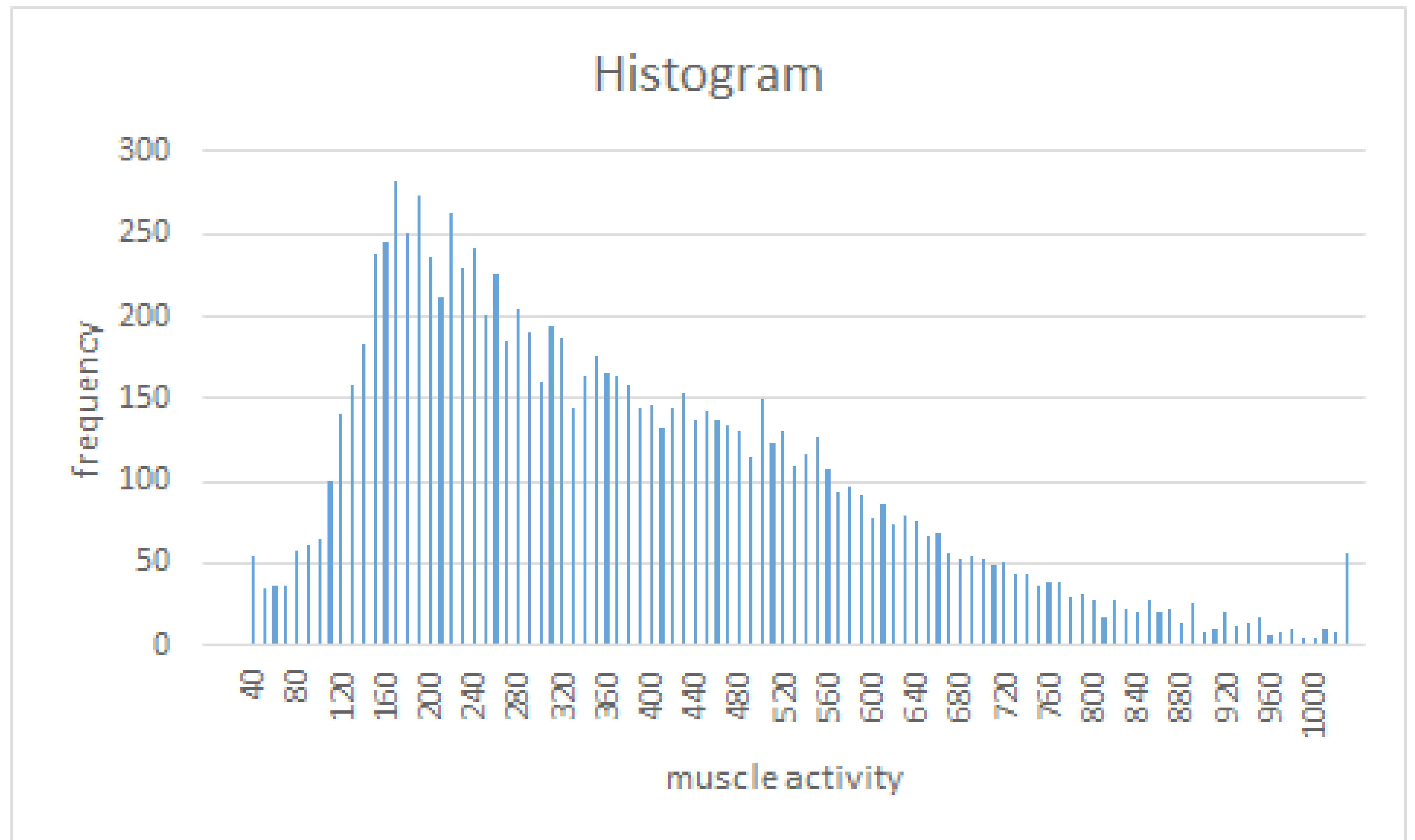

APPLICATIONS

Lower number injuries

Achieving higher results

**Combination with
smartphone application**

Haptic Feedback

**Great for beginners and
semi-advanced**